

STAMFORD®

LVI634F - Technical Data Sheet

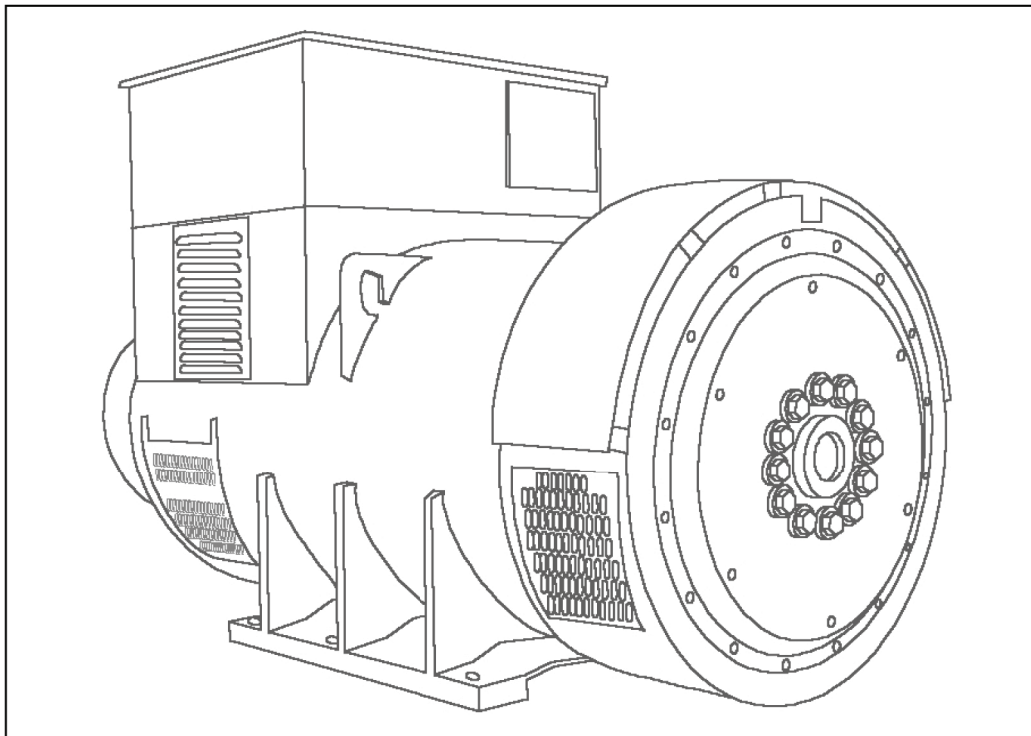

LVI634F

SPECIFICATIONS & OPTIONS

STANDARDS

Newage Stamford industrial generators meet the requirements of BS EN 60034 and the relevant section of other international standards such as BS5000, VDE 0530, NEMA MG1-32, IEC34, CSA C22.2-100, AS1359.

Other standards and certifications can be considered on request.

VOLTAGE REGULATORS

MX341 AVR

This sophisticated AVR is incorporated into the Stamford Permanent Magnet Generator (PMG) control system.

The PMG provides power via the AVR to the main exciter, giving a source of constant excitation power independent of generator output. The main exciter output is then fed to the main rotor, through a full wave bridge, protected by a surge suppressor. The AVR has in-built protection against sustained over-excitation, caused by internal or external faults. This de-excites the machine after a minimum of 5 seconds.

An engine relief load acceptance feature can enable full load to be applied to the generator in a single step.

If three-phase sensing is required with the PMG system the MX321 AVR must be used.

We recommend three-phase sensing for applications with greatly unbalanced or highly non-linear loads.

MX321 AVR

The most sophisticated of all our AVRs combines all the features of the MX341 with, additionally, three-phase rms sensing, for improved regulation and performance.

Over voltage protection is built-in and short circuit current level adjustments is an optional facility.

WINDINGS & ELECTRICAL PERFORMANCE

All generator stators are wound to 2/3 pitch. This eliminates triplen (3rd, 9th, 15th ...) harmonics on the voltage waveform and is found to be the optimum design for trouble-free supply of non-linear loads. The 2/3 pitch design avoids excessive neutral currents sometimes seen with higher winding pitches, when in parallel with the mains. A fully connected damper winding reduces oscillations during paralleling. This winding, with the 2/3 pitch and carefully selected pole and tooth designs, ensures very low waveform distortion.

TERMINALS & TERMINAL BOX

Standard generators feature a main stator with 6 ends brought out to the terminals, which are mounted on the frame at the non-drive end of the generator. A sheet steel terminal box contains the AVR and provides ample space for the customers' wiring and gland arrangements. It has removable panels for easy access.

SHAFT & KEYS

All generator rotors are dynamically balanced to better than BS6861:Part 1 Grade 2.5 for minimum vibration in operation. Two bearing generators are balanced with a half key.

INSULATION/IMPREGNATION

The insulation system is class 'H'.

All wound components are impregnated with materials and processes designed specifically to provide the high build required for static windings and the high mechanical strength required for rotating components.

QUALITY ASSURANCE

Generators are manufactured using production procedures having a quality assurance level to BS EN ISO 9001.

The stated voltage regulation may not be maintained in the presence of certain radio transmitted signals. Any change in performance will fall within the limits of Criteria 'B' of EN 61000-6-2:2001. At no time will the steady-state voltage regulation exceed 2%.

NB Continuous development of our products entitles us to change specification details without notice, therefore they must not be regarded as binding.

Front cover drawing typical of product range.

LVI634F
WINDING 312

CONTROL SYSTEM SER.3	SEPARATELY EXCITED BY P.M.G.							
A.V.R.	MX341	MX321						
VOLTAGE REGULATION	± 1.0 %	± 0.5 %	With 4% Engine Governing					
SUSTAINED SHORT CIRCUIT	REFER TO SHORT CIRCUIT DECREMENT CURVES (page 7)							
INSULATION SYSTEM	CLASS H							
PROTECTION	IP23							
RATED POWER FACTOR	0.8							
STATOR WINDING	DOUBLE LAYER LAP							
WINDING PITCH	TWO THIRDS							
WINDING LEADS	6							
STATOR WDG. RESISTANCE (L-L)	0.0018 Ohms PER PHASE AT 22°C STAR CONNECTED							
ROTOR WDG. RESISTANCE	2.14 Ohms at 22°C							
R.F.I. SUPPRESSION	BS EN 61000-6-2 & BS EN 61000-6-4, VDE 0875G, VDE 0875N. refer to factory for others							
WAVEFORM DISTORTION	NO LOAD < 1.5% NON-DISTORTING BALANCED LINEAR LOAD < 5.0%							
MAXIMUM OVERSPEED	2250 Rev/Min							
BEARING DRIVE END	BALL. 6228 (ISO)							
BEARING NON-DRIVE END	BALL. 6319 (ISO)							
	1 BEARING				2 BEARING			
WEIGHT COMP. GENERATOR	2678 kg				2700 kg			
WEIGHT WOUND STATOR	1148 kg				11.48 kg			
WEIGHT WOUND ROTOR	993 kg				945 kg			
WR ² INERTIA	23.9182 kgm ²				23.375 kgm ²			
SHIPPING WEIGHTS in a crate	2819 kg				2885 kg			
PACKING CRATE SIZE	194 x 105 x 154 (cm)				194 x 105 x 154 (cm)			
	50 Hz				60 Hz			
TELEPHONE INTERFERENCE	THF<2%				TIF<50			
COOLING AIR	2.18 m ³ /sec 4619 cfm				2.63 m ³ /sec 5573 cfm			
VOLTAGE STAR (Y)	380/220	400/231	415/240	440/254	416/240	440/254	460/266	480/277
KVA BASE RATING FOR REACTANCE VALUES	1090	1130	1130	1025	1204	1274	1332	1390
X _d DIR. AXIS SYNCHRONOUS	2.57	2.40	2.23	1.80	2.88	2.73	2.61	2.50
X' _d DIR. AXIS TRANSIENT	0.13	0.12	0.12	0.09	0.15	0.14	0.13	0.13
X'' _d DIR. AXIS SUBTRANSIENT	0.10	0.09	0.08	0.07	0.11	0.10	0.10	0.09
X _q QUAD. AXIS REACTANCE	2.14	2.00	1.86	1.50	2.40	2.27	2.17	2.08
X'' _q QUAD. AXIS SUBTRANSIENT	0.24	0.23	0.21	0.17	0.27	0.26	0.25	0.24
X _L LEAKAGE REACTANCE	0.07	0.06	0.06	0.05	0.07	0.07	0.07	0.06
X ₂ NEGATIVE SEQUENCE	0.17	0.16	0.15	0.12	0.19	0.18	0.17	0.16
X ₀ ZERO SEQUENCE	0.03	0.03	0.02	0.02	0.03	0.03	0.03	0.03
REACTANCES ARE SATURATED				VALUES ARE PER UNIT AT RATING AND VOLTAGE INDICATED				
T' _d TRANSIENT TIME CONST.	0.103 s							
T'' _d SUB-TRANSTIME CONST.	0.014 s							
T' _{do} O.C. FIELD TIME CONST.	3.38 s							
T _a ARMATURE TIME CONST.	0.035 s							
SHORT CIRCUIT RATIO	1/X _d							

**50
Hz**

**LVI634F
Winding 312**

THREE PHASE EFFICIENCY CURVES

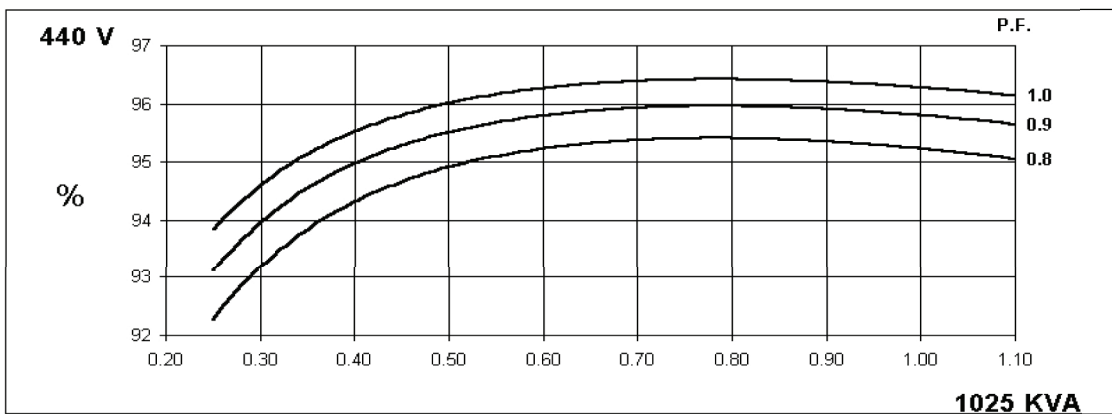
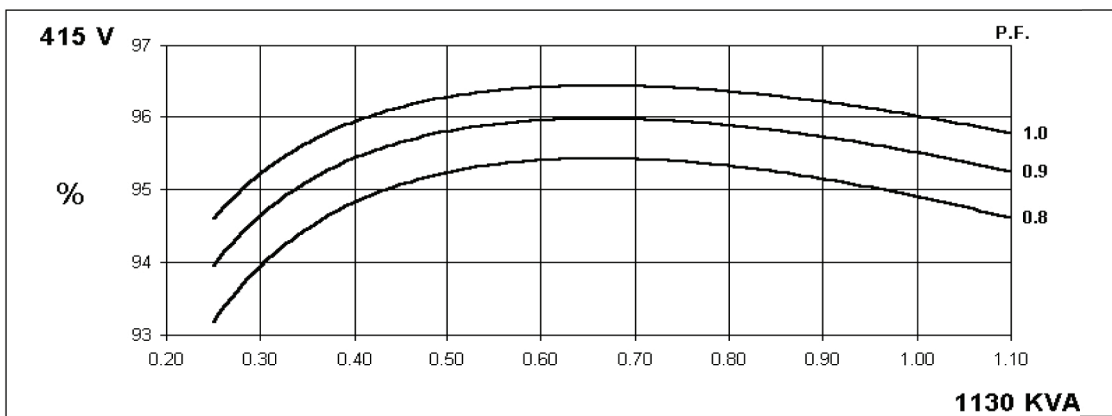
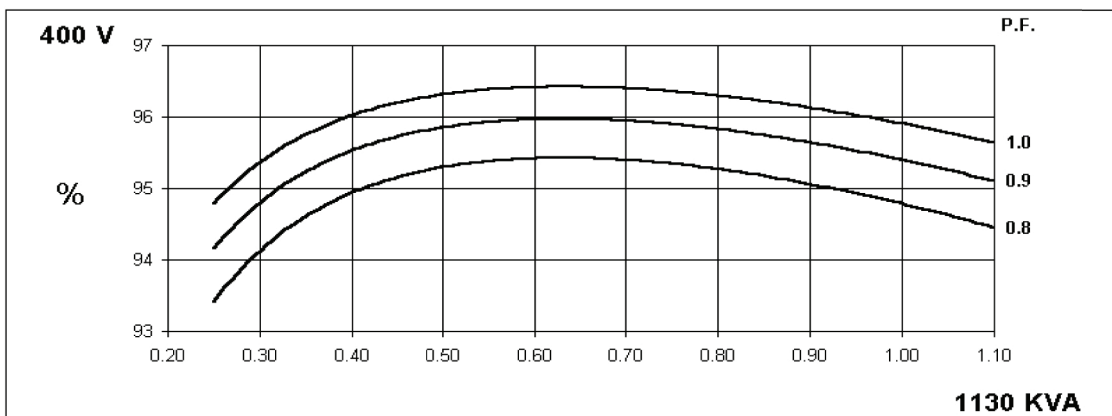
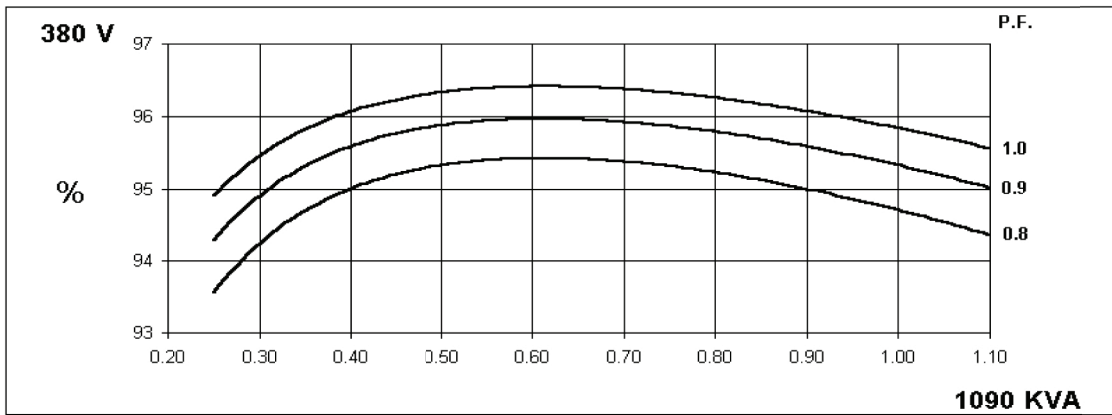

LVI634F
Winding 312

60
Hz

THREE PHASE EFFICIENCY CURVES

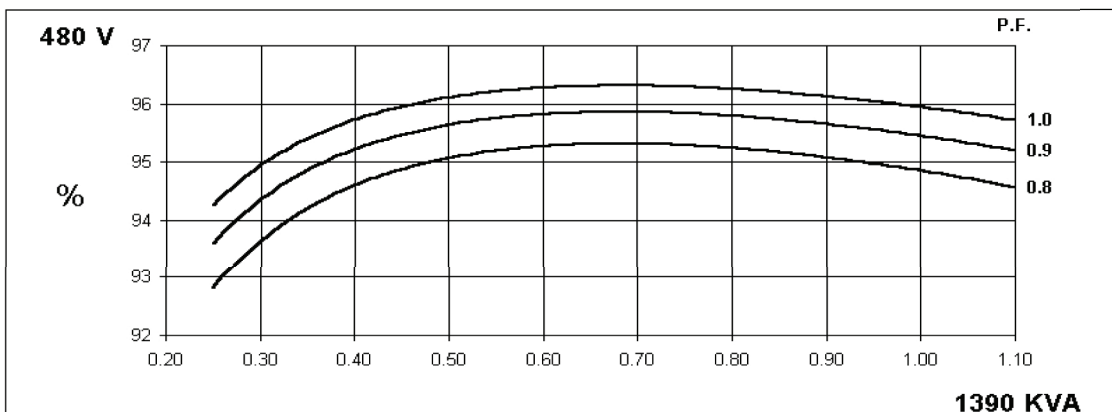
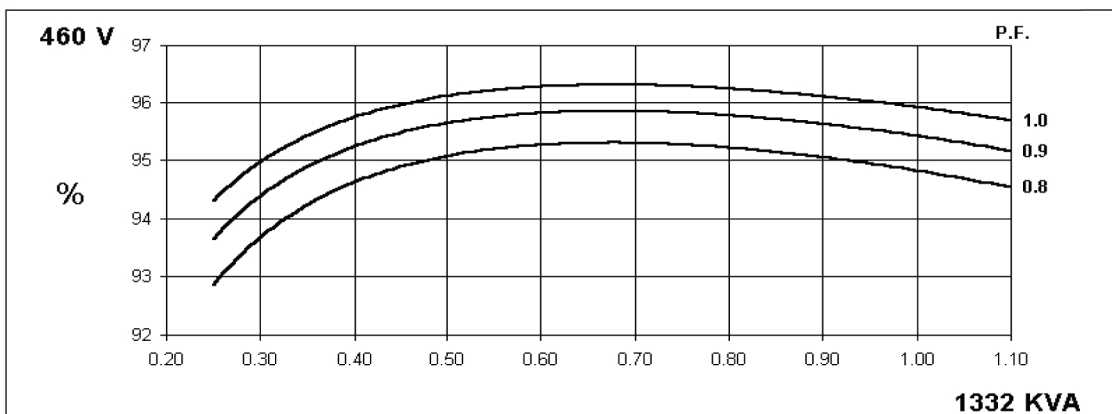
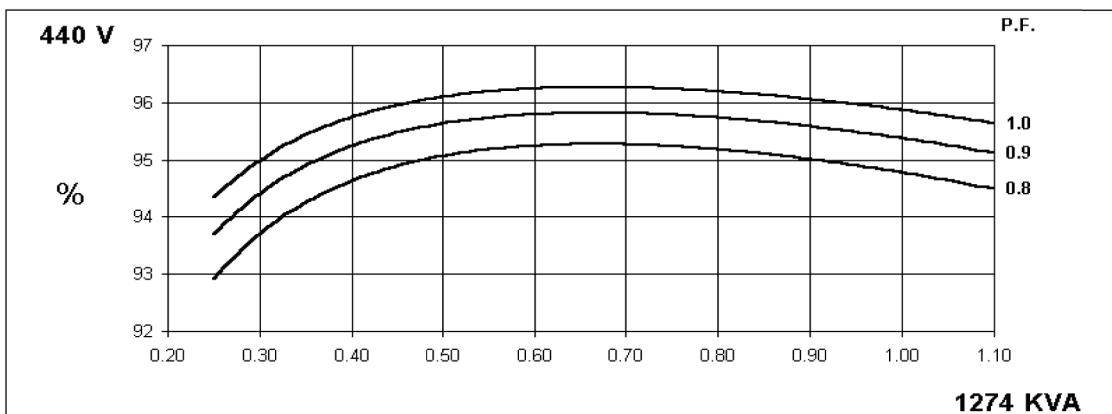
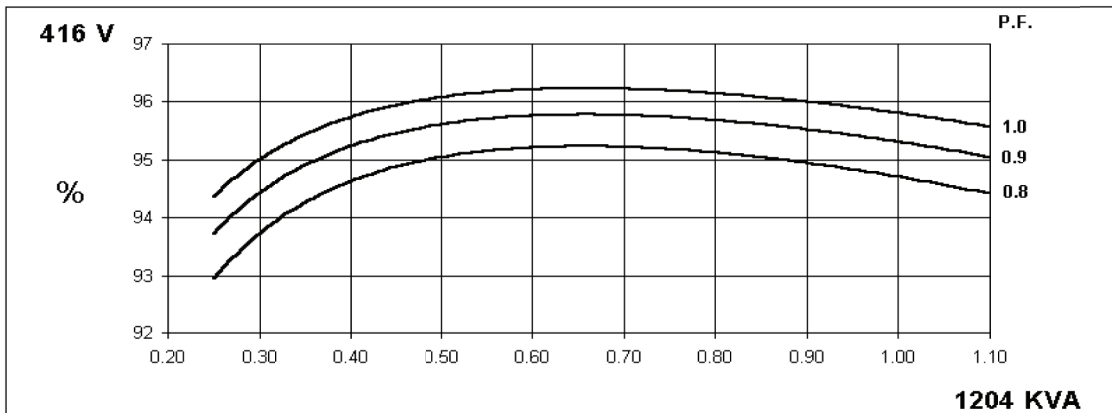

LVI634F
Winding 312

Locked Rotor Motor Starting Curve

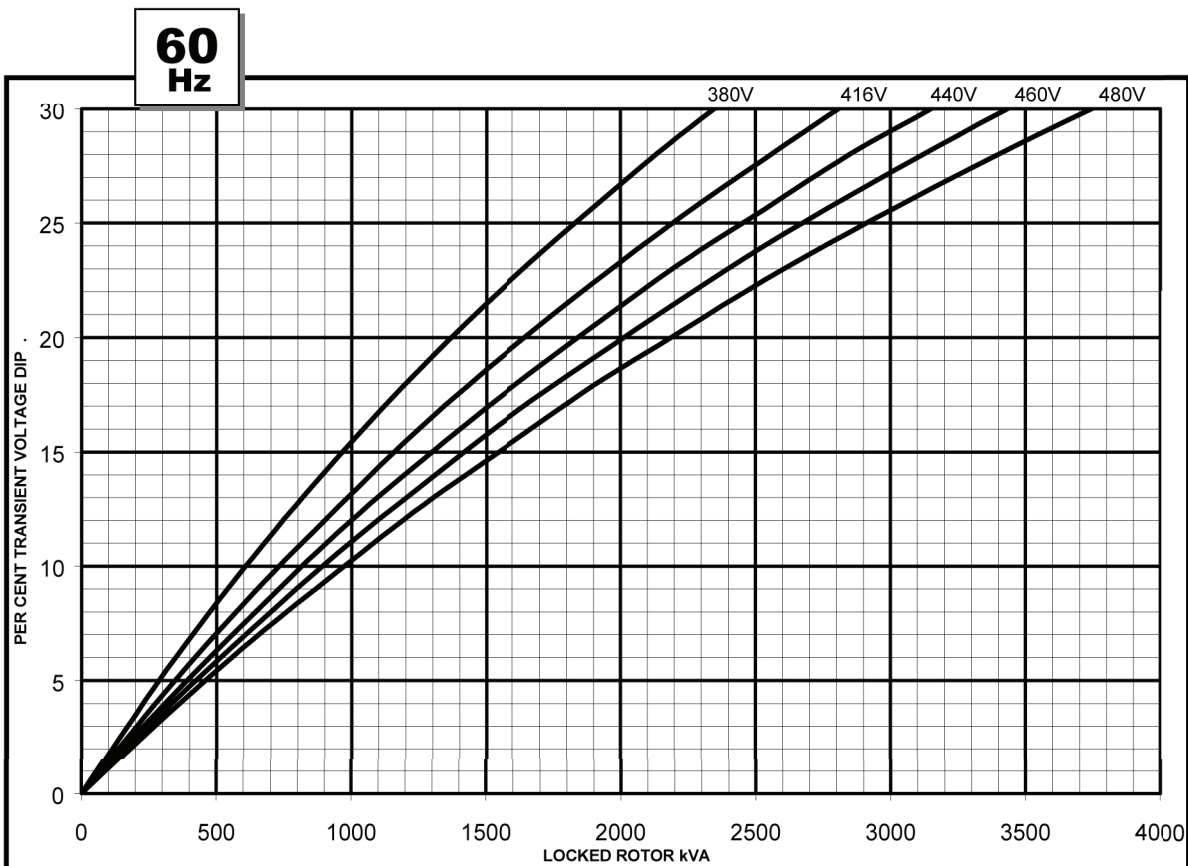
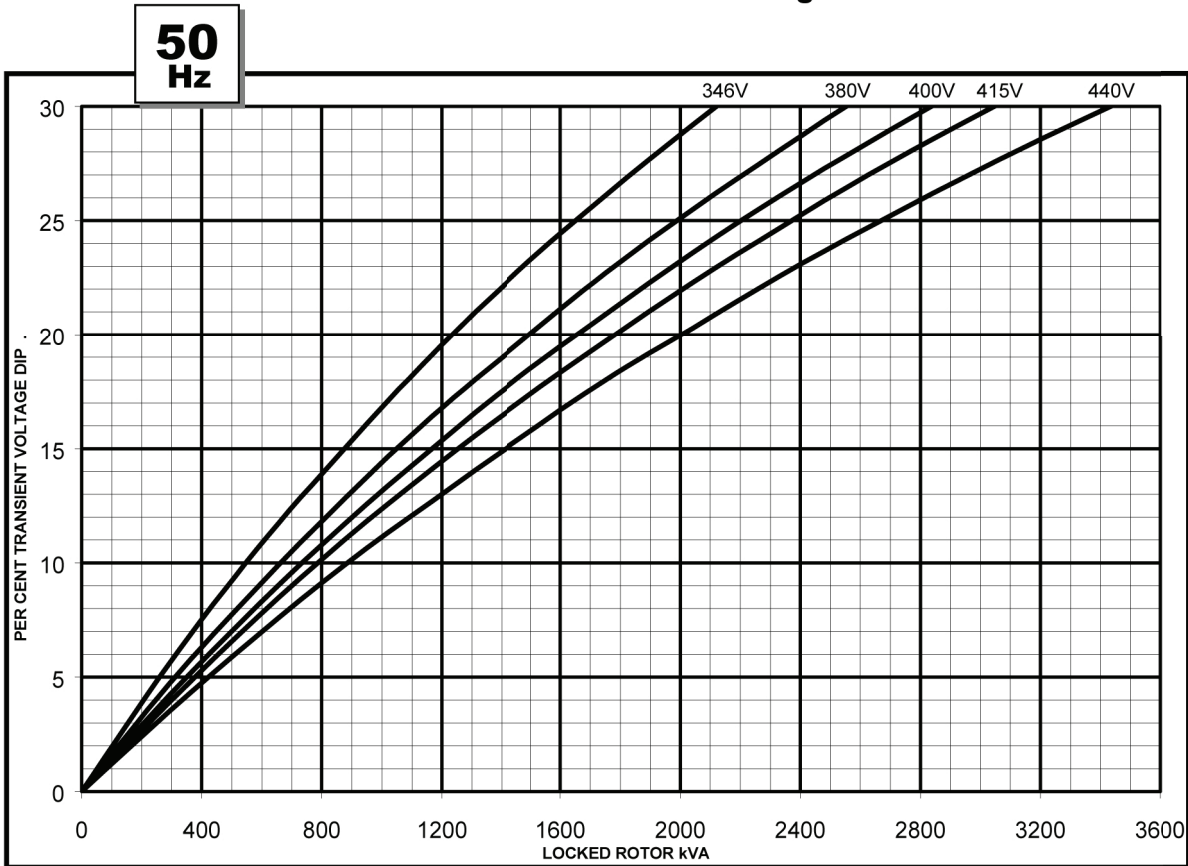

LVI634F

**Three-phase Short Circuit Decrement Curve. No-load Excitation at Rated Speed
Based on star (wye) connection.**

**50
Hz**

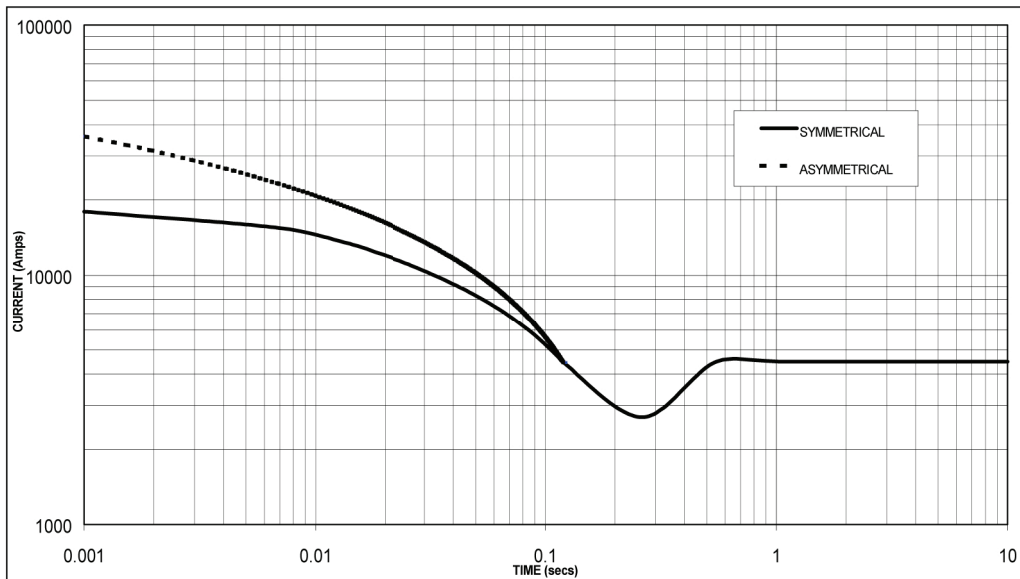

Sustained Short Circuit = 4,480 Amps

**60
Hz**

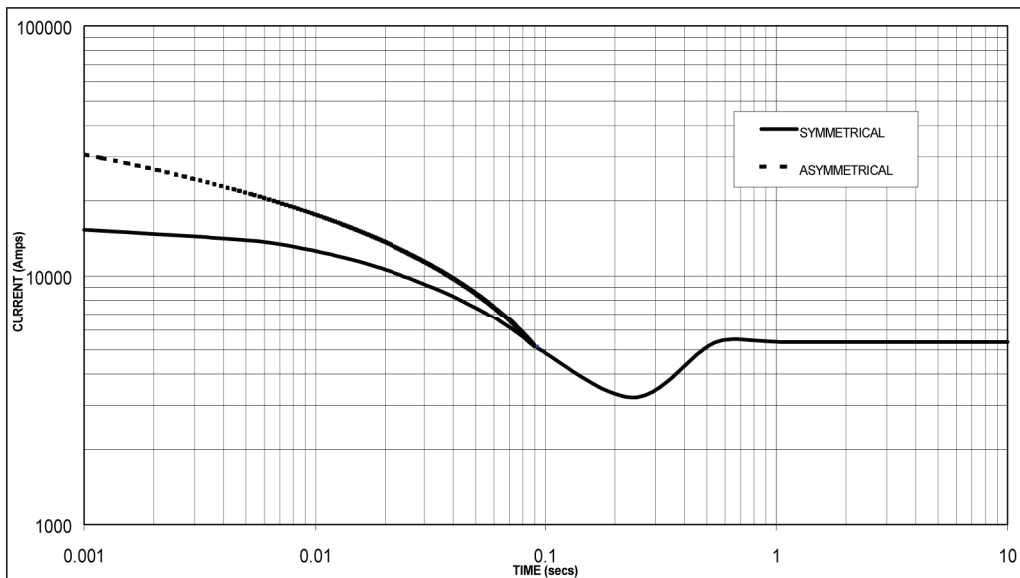

Sustained Short Circuit = 5,630 Amps

Note 1

The following multiplication factors should be used to adjust the values from curve between time 0.001 seconds and the minimum current point in respect of nominal operating voltage :

50Hz		60Hz	
Voltage	Factor	Voltage	Factor
380v	X 1.00	416v	X 1.00
400v	X 1.05	440v	X 1.06
415v	X 1.09	460v	X 1.10
440v	X 1.16	480v	X 1.15

The sustained current value is constant irrespective of voltage level

Note 2

The following multiplication factor should be used to convert the values calculated in accordance with NOTE 1 to those applicable to the various types of short circuit :

	3-phase	2-phase L-L	1-phase L-N
Instantaneous	x 1.00	x 0.87	x 1.30
Minimum	x 1.00	x 1.80	x 3.20
Sustained	x 1.00	x 1.50	x 2.50
Max. sustained duration	10 sec.	5 sec.	2 sec.

All other times are unchanged

Note 3

Curves are drawn for Star (Wye) connected machines.

LVI634F
Winding 312 / 0.8 Power Factor

RATINGS

Class - Temp Rise		Cont. F - 105/40°C				Cont. H - 125/40°C				Standby - 150/40°C				Standby - 163/27°C			
50 Hz	Star (V)	380	400	415	440	380	400	415	440	380	400	415	440	380	400	415	440
	Delta (V)	220	230	240	254	220	230	240	254	220	230	240	254	220	230	240	254
	kVA	999	1035	1035	939	1090	1130	1130	1025	1125	1165	1165	1055	1145	1185	1185	1075
	kW	799	828	828	751	872	904	904	820	900	932	932	844	916	948	948	860
	Efficiency (%)	94.8	94.9	95.0	95.3	94.6	94.7	94.8	95.1	94.5	94.6	94.7	95.1	94.4	94.5	94.7	95.1
	kW Input	843	872	872	788	922	955	954	862	952	985	984	887	970	1003	1001	904

60 Hz	Star (V)	416	440	460	480	416	440	460	480	416	440	460	480	416	440	460	480
	Delta (V)	240	254	266	277	240	254	266	277	240	254	266	277	240	254	266	277
	kVA	1104	1167	1220	1274	1204	1274	1332	1390	1243	1315	1375	1435	1257	1329	1390	1450
	kW	883	934	976	1019	963	1019	1066	1112	994	1052	1100	1148	1006	1063	1112	1160
	Efficiency (%)	94.8	94.9	94.9	95.0	94.6	94.7	94.7	94.7	94.5	94.6	94.6	94.7	94.5	94.5	94.6	94.6
	kW Input	932	984	1028	1073	1018	1076	1125	1174	1052	1112	1163	1212	1064	1125	1175	1226

DIMENSIONS

